

Det Kgl. Danske Videnskabernes Selskab.
Mathematisk-fysiske Meddelelser. **XVIII**, 1.

A HIGH TENSION APPARATUS FOR NUCLEAR RESEARCH

(INSTITUTE FOR THEORETICAL PHYSICS, COPENHAGEN)

BY

T. BJERGE, K. J. BROSTRØM, J. KOCH,
AND T. LAURITSEN



KØBENHAVN
EJNAR MUNKSGAARD

1940

Printed in Denmark
Bianco Lunos Bogtrykkeri A/S

Introduction.

The discovery by RUTHERFORD of the nucleus of the atom in 1911 and his subsequent proof (1919) that atomic nuclei may undergo transformations when struck by high speed alpha particles from natural radioactive substances initiated, as is well known, a whole new development in physics. A great advance in this field was brought about by the experiments in the Cavendish Laboratory in 1932 by COCKROFT and WALTON, demonstrating that such nuclear transformations can also be produced by bombardment with positive ions accelerated in high tension acceleration tubes. In view of the interest in nuclear physics at this Institute, it was a natural consequence that plans should be made to construct in Copenhagen an apparatus similar to that at the Cavendish Laboratory to give opportunity for experimental work in close cooperation with the theoretical investigations being carried on here.

Realisation of these desires first became possible in 1935 by grants to Professor BOHR from the Carlsberg Foundation and Rockefeller Foundation of sufficient funds to enable the acquirement of a one million volt high tension generator and the erection of a suitable building to house the generator and appertaining equipment. Negotiations for a practical and economical design of a generator suited to the particular purpose in view and sufficiently flexible to make possible its more general application were at once taken up with the KOCH & STERZEL company by Professor v. HIPPEL,

who was at that time in residence at the Institute working on problems on electrical discharges in insulators. A practical and economical plan for the generator was completed in 1936, and construction begun by the company.

Erection of the building and installation of the generator occupied about two years, during which time preparatory work on the accelerating tube was carried out with frequent consultations with Drs. J. D. COCKROFT, P. I. DEE, and M. L. E. OLIPHANT at the Cavendish Laboratory, who most kindly placed their great experience at our disposal (1). In the spring and summer of 1938, after completion of the technical installation, the tube was set up and run for some time as an X-ray source in order to gain experience with the plant and, at the same time, to investigate its practicability as a therapeutically useful source of high voltage radiation. The preliminary work and adjustment of the tube was greatly facilitated by the help of Professor C. C. LAURITSEN, then a visitor to Copenhagen.

With the completion, in the fall of 1938, of test work on a positive ion source, the potential on the set was reversed and the tube adjusted to accelerate deuterons. At this point in the work, the discovery by HAHN and STRASSMANN of the fission of uranium by neutrons and the immediately following detection by O. R. FRISCH (2) at this Institute of the enormously energetic particles emitted in the process made it highly desirable to use the plant as a neutron source in order to enable study of the fission phenomenon with higher intensities. All efforts were, therefore, devoted to getting the tube in working order as rapidly as possible and, in February 1939, a neutron source equiva-

¹ One of us (J. K.) is indebted to the Justitsraad S. A. Bojesens Studiefond for a stipend permitting a visit to Cambridge.

² O. R. FRISCH, *Nature* **143**, 276 (1939).

lent to about 100 curies of radium-beryllium was produced by bombardment of lithium with a deuteron beam of about 900 kV and 50 microamperes. This source was used in experiments by Dr. FRISCH and Professor MEITNER (1) on the chemical properties of the fission products, in a study of the associated decay periods by BJERGE, BROSTRØM and KOCH (2), and in an investigation of the delayed neutron emission by BROSTRØM, KOCH and LAURITSEN (3).

As the plant came into regular use, it became evident that certain features could be improved. Particularly, as the working voltage of the generator was gradually increased to about 1000 kV, sparks to the wall of the laboratory were not infrequent and several times caused the destruction of one of the rectifier tubes. For this reason, at the suggestion of Professor LAURITSEN, it was early decided to construct a continuously evacuated porcelain rectifier column to replace the standard equipment, and work begun on the necessary parts. Finally, in September 1939, a discharge occurred which not only punctured a rectifier but also caused a breakdown in a high voltage transformer, necessitating its removal and repair. This opportunity was used to make the necessary changes in the plant and to erect the rectifier column.

In February 1940, the plant was again in running order, working steadily up to a potential of about 850 kV. Since that time, the outfit has run on the average about 15 to 20 hours per week as a neutron source, largely used in a Wilson cloud chamber study of fission tracks (4). In

¹ O. R. FRISCH and L. MEITNER, *Nature* **143**, 471 (1939) and *D. Kgl. Danske Vidensk. Selskab, Math.-fys. Medd.* XVII, 5, 1939.

² T. BJERGE, K. J. BROSTRØM and J. KOCH, *Nature* **143**, 794 (1939).

³ K. J. BROSTRØM, J. KOCH and T. LAURITSEN, *Nature* **144**, 830 (1940).

⁴ K. J. BROSTRØM, J. BOGGILD and T. LAURITSEN, *Phys. Rev.* in press.

addition, the plant has been frequently used in the preparation of radioactive substances for the physical-biological researches carried out in the Institute by Professor HEVESY and his collaborators. It is now felt that the installation has reached a stage of efficiency and reliability within its scope sufficient to enable further scientific work to be carried on without essential interruption by apparatus failures and to justify a description here of its principal features.

I. Building arrangements.

A plan of the building erected to house the high tension laboratories is shown in Fig. 1. Its principal feature is a large hall dimensioned to provide sufficient electrical clearance around the one million volt generator and accelerating tube. The floor of the hall is 3 meters below ground level, and an underground passage connects it with the main building of the institute.

The generator is mounted on the floor in the south end of the high tension hall at the position indicated. In the north end, a small room is partitioned off to serve as an observation room and laboratory. The ion tube is mounted on the roof of this hut, and an extension projects into the room for easy accessibility. This roof is supported by an iron construction and consists of two layers of concrete blocks which are 7 cm thick and are made removable for convenience in putting holes through the roof. The weight of the roof is 0.3 tons/m², but the iron construction is designed to carry two tons/m² in case this amount should prove necessary for special purposes. Subsequent measurements, after the plant was in running order, have indicated that the shielding of the roof is quite adequate for protection

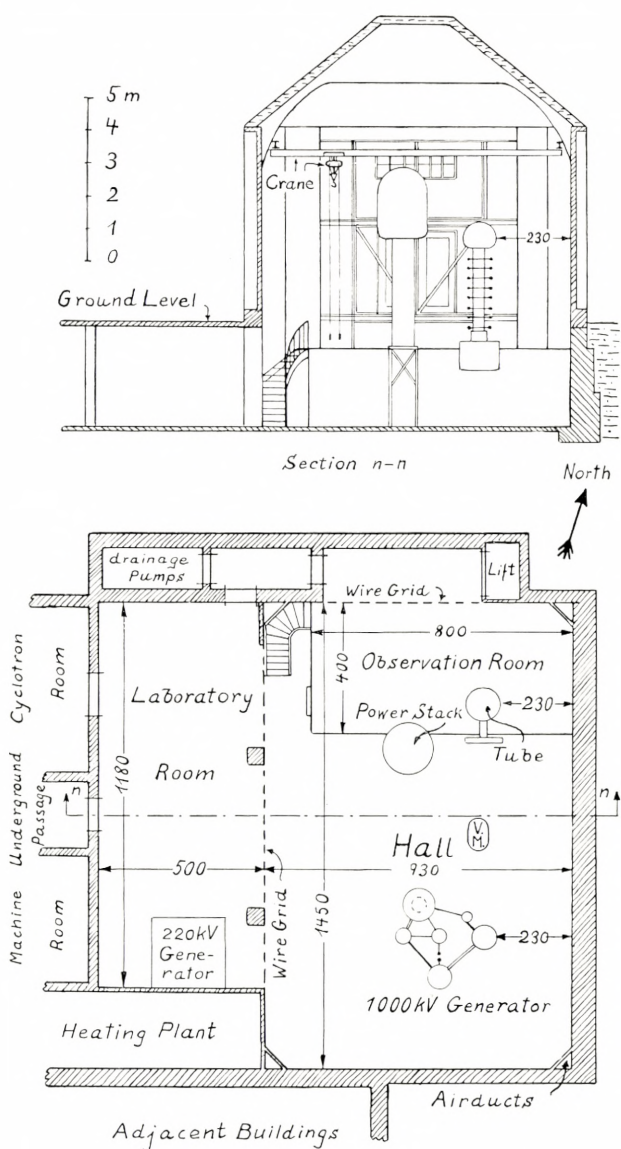

Fig. 1. Plan of building with high tension hall and adjoining laboratories, indicating also the position of the high tension equipment.

against X-radiation, the intensity in this room being below the normal tolerance dose. It appears that the greatest proportion of the X-radiation from the tube is of a very soft character, and easily absorbed.

In order to shield this research room from electrical disturbances, its roof and the wall separating the room from the hall are lined with 0.5 mm. iron sheet. The floor, walls and ceiling of the hall itself are also lined with a grounded netting under the plaster. Nevertheless, experience showed that high frequency disturbances could pass into the room and that it was necessary further to protect sensitive electrical apparatus inside by special shielding.

A travelling crane of 1.5 tons capacity facilitates the handling of large apparatus in the hall. Another laboratory room separated from the hall by a removable wire grid contains a smaller high tension plant of 220 kV for other experimental work. The heating of the whole building is accomplished by a special heating plant by means of which warm air is forced in at the bottom and cold air removed at the top of the airducts in the corners of the hall. An air filter in the plant serves to remove dust from the circulating air which otherwise would be deposited on the high tension conductors and insulating surfaces.

II. The high tension set.

The high tension apparatus as originally delivered by KOCH & STERZEL could produce a constant potential of one million volts and, at somewhat lower voltages, a current of ten milliamperes. It consists of four Greinacher voltage doubling circuits I—IV arranged in cascade, as schematically shown in Fig. 2. The four high tension transformers A_1 — A_4 have a peak voltage of 125 kV and are excited by a set

of special insulation transformers B_1 — B_4 , each fed from the one below.

Under operation, the point a_1 is charged up to 125 kV through the transformer A_1 and rectifier V_1 , while b_1 oscillates between 0 and 250 kV, charging c_1 , through rectifier V_1' to 250 kV. In this manner, the potential at junction points a_1 — c_4 on the condenser column increases progressively upwards to a value of 1000 kV at the top of stage IV. The potentials of the insulation transformers are fixed by connections to the condenser column at each of these points.

The condensers have a capacity of 20,000 cm each, so that the whole capacity of the condenser column is 2,500 cm. The Siemens-Reiniger rectifier tubes supplied with the apparatus are designed for 320 kV inverse peak voltage; here they are used at 250 kV maximum. Current for the filaments is provided by two sets of insulated low voltage generators driven by common turbonite shafts.

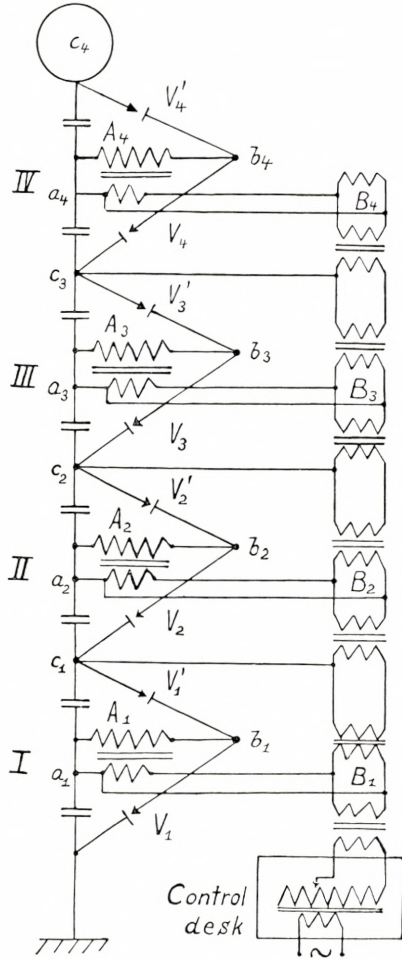

Fig. 2. Electrical circuit of the generator showing the four Greinacher sections I—IV mounted one on top of the other. A_n : High tension transformers. B_n : Feeding transformers. V_n : Rectifier tubes.

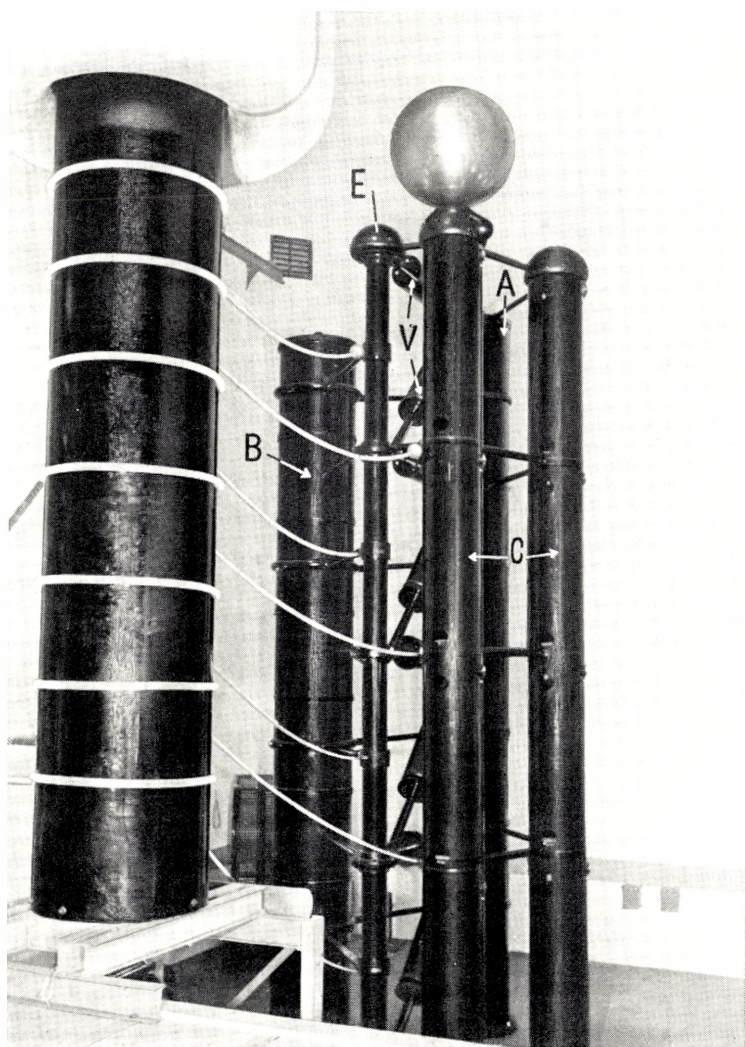

Fig. 3 a. View of generator set seen from the roof of the observation room. A: high tension transformers. B: feeding transformers. C: Generator columns for filament current. E: condenser column. V: rectifier tubes.

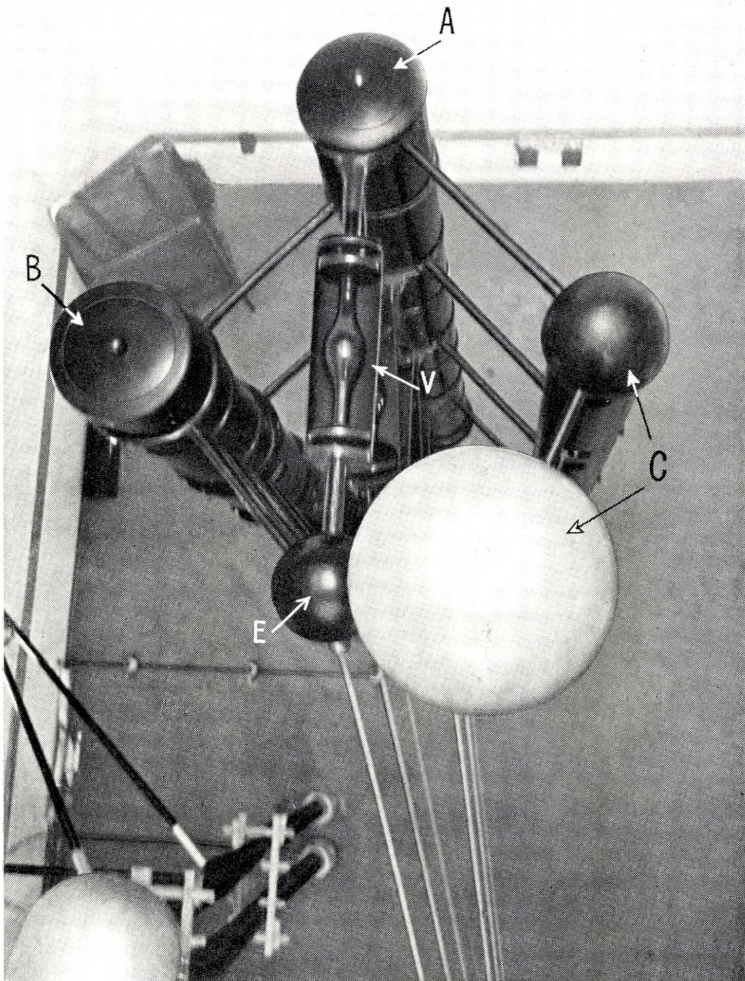

Fig. 3 b. View of generator seen from the roof of the hall. *A*: high tension transformers. *B*: feeding transformers. *C*: Generator columns for filament current. *E*: condenser column. *V*: rectifier tubes. See also Fig. 8.

The potential of the apparatus can be varied in steps of about 5 kV from zero to one million volts by means of a variable transformer in the primary power supply (0—550 volts, 50 cycles). This transformer, together with a primary voltmeter and ammeter and the necessary

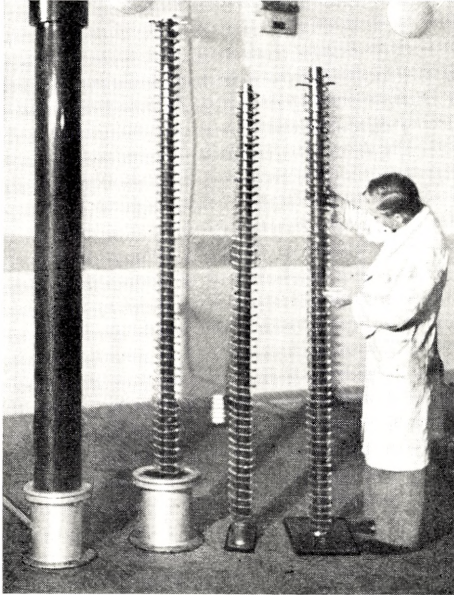

Fig. 4. Voltmeter resistance before assembly.

control instruments, is housed in a portable control desk. Special circuits prevent the operation of the high tension plant unless the doors to the hall are closed, and a time delay circuit breaker prevents overloading.

The diagram of Fig. 2 shows the arrangement of connections for positive potentials; negative potentials can be obtained by simply reversing the rectifier tubes. The apparatus can be made to function as a set of transformers in cascade with a peak a. c. voltage of 500 kV by removing the rectifiers and making the appropriate connections. A one million volt condenser of 2,500 cm capacity was supplied with the apparatus and can be combined with it to make a two million volt impulse generator by the principle given by MARX. These last arrangements have so far not been used for experimental work in this laboratory.

The plant is grounded by means of a copper plate buried under the building to which the metal shielding in the walls of the hall is also connected. Investigations with Lichtenberg's figures and with glow lamps indicate that no potentials of any important magnitude are developed between this ground and others in the laboratory (city ground, water lines, etc.) during high voltage discharges to the walls of the hall.

The actual arrangement of the apparatus is shown in Fig. 3 (a, b). Here are shown the high tension- and feeding transformer columns (A, B), the columns containing the filament current generators (C), and the condenser column (E). The rectifier tubes (V) are suspended between the columns where they connect the high tension transformers with the condensers. This construction prevents

the accumulation of charges from the air on the surfaces of the tubes and the consequent danger of puncture, because the electrical field strength in the space between the columns is relatively small. A pair of copper spheres

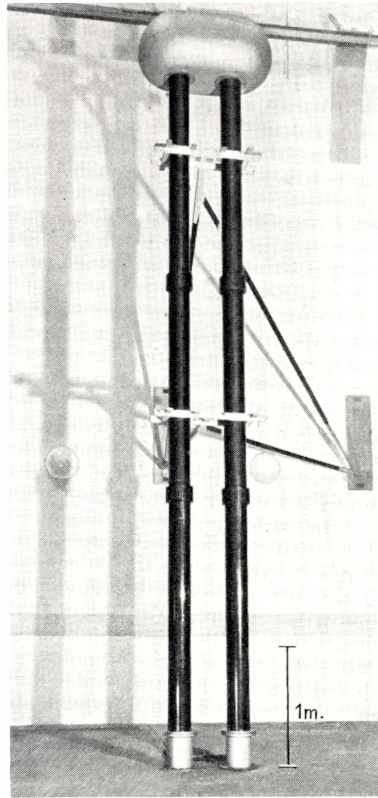

Fig. 5. Voltmeter resistance. The left column serves as mechanical support and as a part of the oil circulation system.

of 100 cm diameter were provided to enable voltage measurements by the spark gap method. For various reasons, we have adopted another method of voltage measurement (to be described later), but at the time this picture was taken we had not yet removed the lower sphere. The overall height of the plant is 8.4 m, and the smallest distance to the walls of the room is 2.30 m (see Fig. 1).

At voltages above 900 kV, some difficulty was encountered in the form of excessive corona discharge and occasional sparking to the south wall. It was found that smoothing the offending surface with a layer of glaziers' putty was effective in less serious cases, but was not sufficient at this point. Following the experience of MARX (1), various paper screens were tried in an attempt to distribute the potential between the top of the transformer column and the wall in such a way as to reduce the corona. After several unsuccessful experiments with screens floating in potential, it was found that a quite small triangular screen with two fine wires laid in the seams and connected to a point at about half potential could almost completely remove the tendency to sparking. Because of the high capacity of the plant, disturbances due to humidity and changes in temperature have not been observed.

Since, for many purposes, it is desirable to have a more convenient and accurate means of measuring the voltage of the set than the spark gap method originally used, we have constructed an ohmic resistance voltmeter of 10^9 ohms, according to principles already developed elsewhere. The resistance, shown in Fig. 4 prior to assembly, consists of 1000 one-megohm Siemens radio resistors mounted on metal pins in a helix around a 60 mm turbonite tube. In

¹ E. MARX, *Elektrotechn. ZS.* **51**, 1161 (1930).

its completed form (Fig. 5), it is enclosed in another turbonite tube of 20 cm diameter and cooled with circulating oil. The use of metal in the joints of the outer cylinders is avoided to prevent extraneous corona currents. One column serves for mechanical support and as part of the oil circulating system. The overall height of the resistance is 6.8 m, in order that the corona shield on top shall come to about the same height as the corresponding point in the high tension plant. The system is further supported from the walls of the hall by members of turbonite and paraffined wood. The power loss in the resistance, of one kilowatt maximum, does not warm the resistances appreciably, even without oil-circulation. Milliammeters on the control desk and in the observation room measure the current down the resistance and thus indicate the voltage.

III. The rectifier column.

Because of the liability to puncture and the difficulty and expense of replacement of the sealed-off glass rectifier tubes, a continuously evacuated set of porcelain rectifier tubes was built and, after separate testing, installed as an integral part of the high tension generator.

In order to fit in geometrically and electrically with the existing plant, the tubes were arranged in a column of eight sections, one above the other, with a common pumping system. Fig. 6 is a sketch showing the construction of the lowest stage of two sections. The flange *F* supports a tubular shield on the top end of which is mounted a perforated plate *P* carrying the anode of the next rectifier section while the bottom end projects down to shield the porcelain in the section below. The filament holder *C* is mounted on

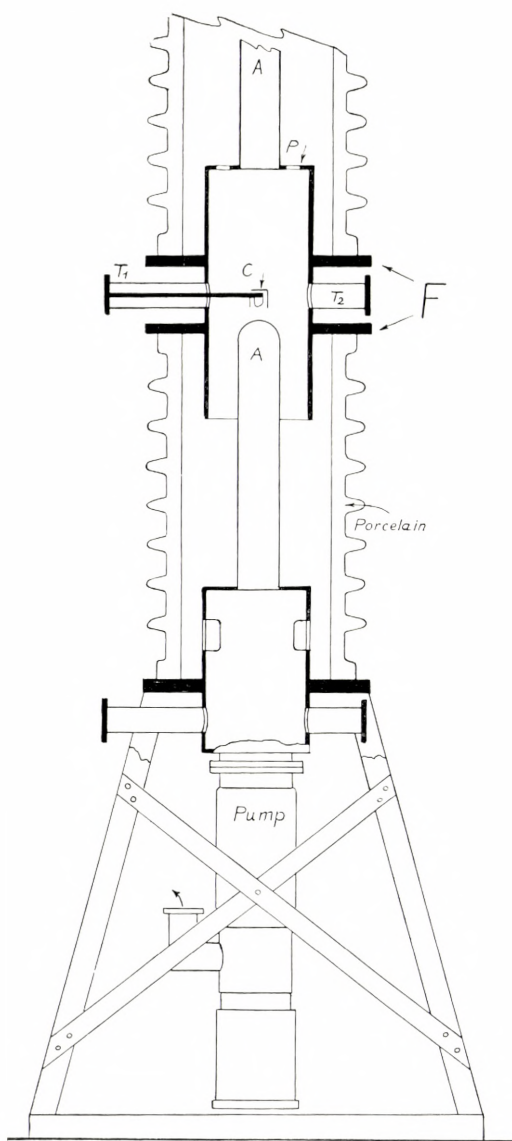

Fig. 6. First stage of rectifier column connected with a 5" oil diffusion pump. *F*: Flange separating the different sections. *P*: Perforated plate carrying anode. *C*: Cathode which can be removed through the tube *T*₁.

a side tube T_1 welded into the flange and is removable. Two filaments are mounted in the holder and contacts outside permit changing over in case of failure of the one, without breaking the vacuum seal. The anodes A are hemispherical on the end and are highly polished to prevent cold emission on the reverse half cycle. An extra side tube T_2 is provided to allow installation of a switching arrangement for reversing potential but, since this mechanism has never been constructed, the tube is closed with a glass plate and used for inspection.

Preliminary experiments showed that operation with completely unshielded filaments was impossible; accordingly, the filament holders were provided with cups as indicated which shielded in all directions except that of the anode. It has been found that the filament should be placed just within the cup, as operation is very unsteady if the filament projects into the high field, and the potential drop becomes too high if it is placed too deeply in the cup. For reasons of mechanical stability, a hairpin filament of 0.3 mm tungsten wire is used. The internal resistance of the rectifier with such a filament is of the order of 30,000 to 60,000 ohms, as compared with the value of 20,000 ohms specified for the original tubes furnished with the set. At 9.5 amperes heating current, the saturation current is of the order of 100 milliamperes. Under normal conditions, a filament can run for several hundred hours.

It was at first thought that a more effective electrical separation of sections, particularly between the four Greinacher stages, than that provided by the perforated plate supporting the anode might be necessary, but there is no indication that such is the case. A baffle was mounted above the plate separating the lower two stages but seemed to have no

effect on the operation. It was, however, found to be essential to baffle the vacuum pump with great care, as the gradual diffusion of oil vapour into the lower sections

caused very unsteady behaviour.

In a vacuum system which cannot be outgassed by baking, occasional discharges, due to the effect of gas adsorbed on the electrodes, must be expected when voltage is first applied after having been off for some hours. Such disturbances, because of the large capacitance in the circuits, can cause very violent shocks to the high voltage transformers which can easily destroy them, if suitable precautions are not taken. For this reason, it was considered advisable to install protective

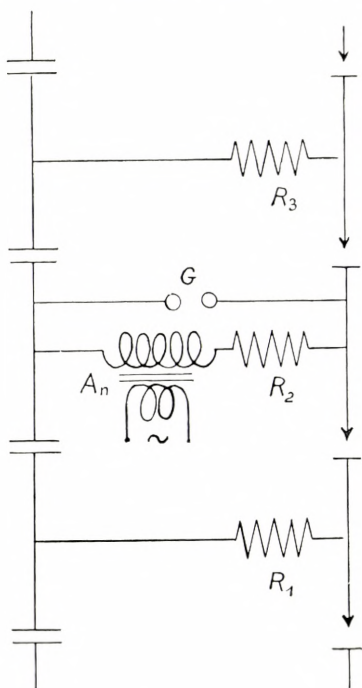

Fig. 7. Diagram of one stage of the modified circuit of the generator with the resistances R_1 , R_2 , R_3 and the spark gap G in order to protect the high tension transformer A_n .

electrical surges to go around the transformer. The present circuit is shown in Fig. 7. For the resistances R_{1-3} suspended water hoses with a 6 mm bore, about 150 cm in length and provided with expansion vessels at the ends, seems to be satisfactory. Such a water resistance has, in addition to the advantages of simplicity and cheapness,

the feature that its resistance rises very rapidly on overloading, by the formation of steam bubbles in the hose.

With the present arrangement, the set is able to operate

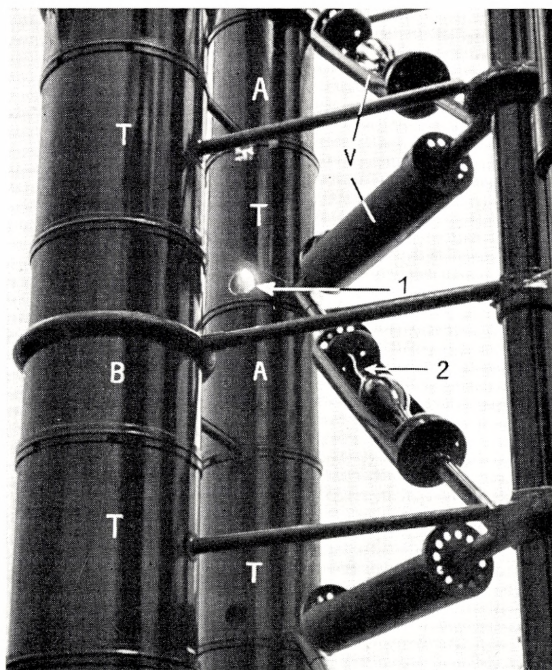

Fig. 8. Photograph of discharge between two high tension transformers (arrow 1) and along a rectifier tube (arrow 2). The figure shows the arrangement of the rectifier tubes and the columns with the high tension transformers (A) and feeding transformers (B) separated by supporting tubes (T).

at a maximum potential of about 900 kV with steady operation at 800—850 kV. When it is first started in the day, the filaments are allowed to run for five to ten minutes, after which voltage can be run up to 700—750 kV. Ordinarily, full voltage can be applied after 15 minutes to a half hour's running. As the individual stages of the

rectifier have been run separately to 280 kV, it is believed that the plant would be quite capable of going up to 1000 kV, if the transformers could supply the power required. Because of the potential drop in the protective resistances, the constant potential delivered by the set is somewhat less than that corresponding to the peak potentials of the transformers, which cannot safely be allowed to exceed 1000 kV.

To show the kind of devastating discharges that can appear in the absence of such protection, a photograph (Fig. 8) is here reproduced which was obtained incidentally to a search for a mysterious sparking, by a camera set up with open shutter in the hall. Actually, the discharge photographed was the one mentioned in the introduction, which caused the destruction of one of the transformers and a rectifier tube. In addition to the spark inside the turbonite support separating two high tension transformers (arrow 1), a fine spark is visible along one of the rectifier tubes, puncturing it at the seal-off projection (arrow 2).

A comparison of Fig. 8 with Fig. 9, which is a recent picture of the set, showing the rectifier column in position, will give an idea of the extent of the alterations in the whole construction. To provide the necessary clearance, the condenser column was moved from its original position to one nearer the column containing the feeding transformers, and some of the iron braces were replaced by turbonite tubing. The sphere on top of the generator column has been removed as it was found to be unnecessary at this stage.

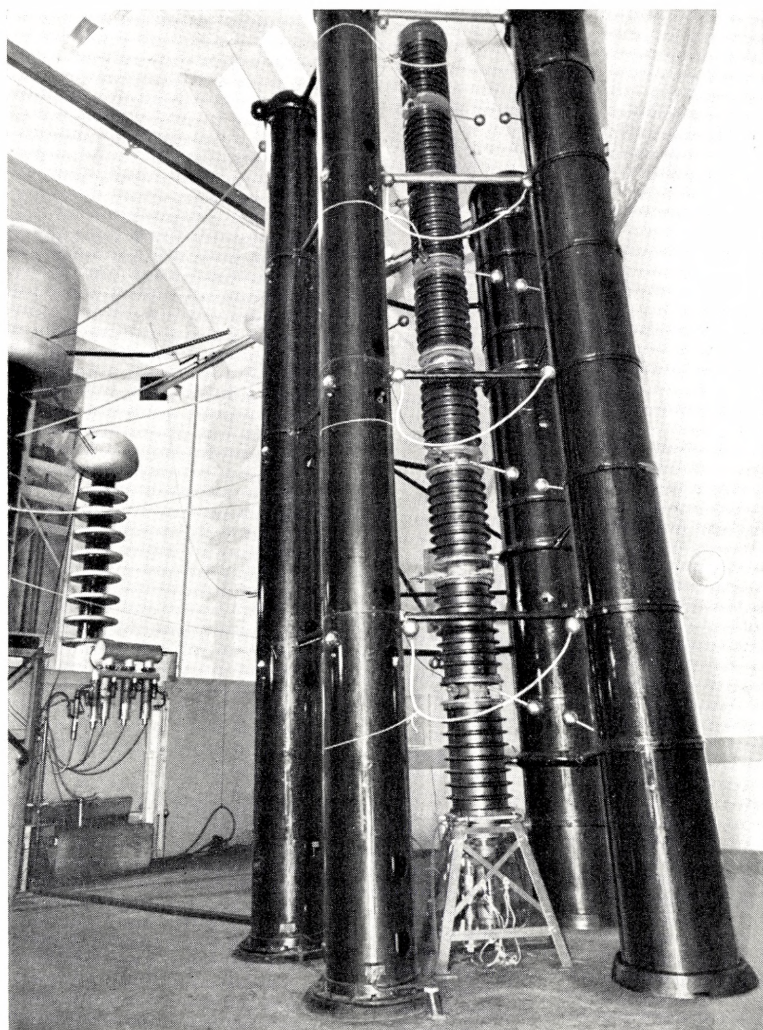

Fig. 9. View from south-west corner of the hall showing generator with rectifier column, spark gaps and protective resistances (photographically distorted).

IV. The ion production and acceleration system.

The general arrangement of the ion tube and appertaining equipment is shown in the photograph of Fig. 10. To the right on the roof of the observation room is seen the acceleration tube, capped with a hemispherical corona shield containing the ion source. On the wall of the room, connected to the tube by a 10 inch vacuum line, are the vacuum pumps. To the left is an insulating column supporting a power plant for the ion source and, at the same time, serving as support for the connections from the high tension generator to the individual sections of the tube. The smallest clearance from the tube to the walls is 2.3 m, which seems to be sufficient except at voltages above 950 kV, where occasional discharges take place when the tube is unsteady. A more detailed description of the individual parts of the apparatus is given in the following.

a) Ion source.

The ion source is of the high tension discharge type developed in the Cavendish Laboratory. This type was chosen because of its proved reliability and the ease of focussing. Fig. 11 is a drawing of the ion source following, with only minor alterations, drawings very kindly supplied us by Professor OLIPHANT. "A" is the anode, a steel cylinder, 8 cm in diameter, mounted coaxially with the cathode "C" with about 6 mm clearance at the sides and 8 mm at the bottom. The anode cylinder is screwed on the end of an oil-cooled projection welded to the upper flange. A 25 mm thick glass plate "G" insulates the anode from the cathode, and the joints between the iron flanges and the glass plate are made tight with rubber gaskets and glyptal lacquer.

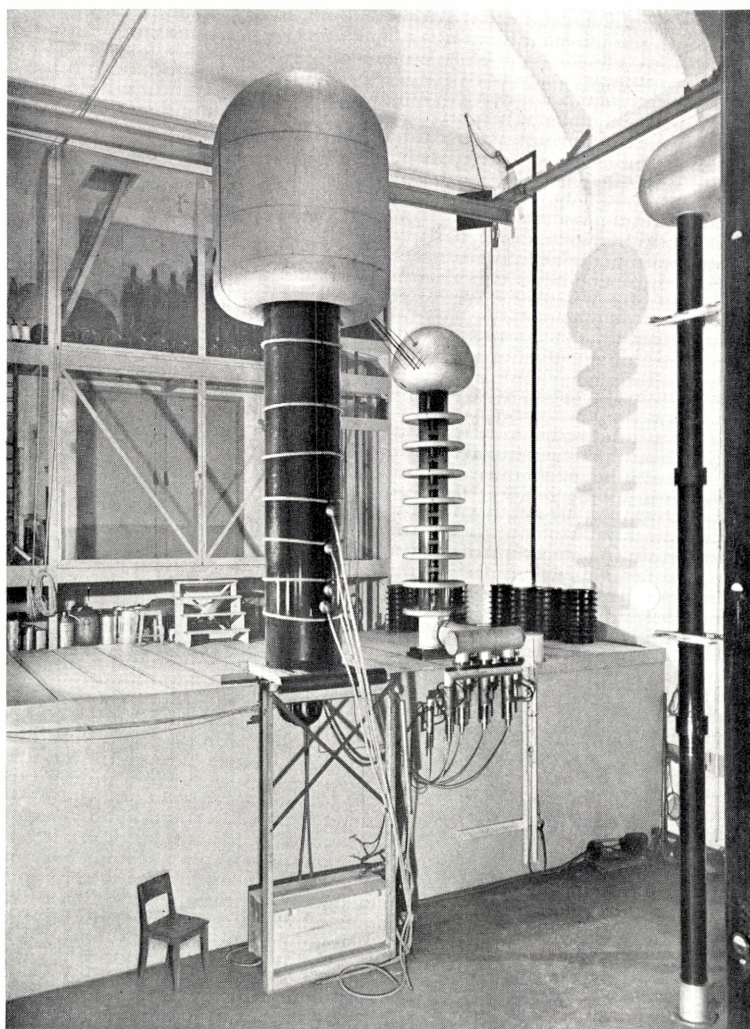

Fig. 10. Acceleration tube and power stack mounted on top of the observation room. To the extreme right is seen the high tension resistance and a part of the generator.

The cathode cylinder is provided with a bottom threaded in, containing a conical insertion with the canal which is 1.5 mm in diameter and 6 mm long.

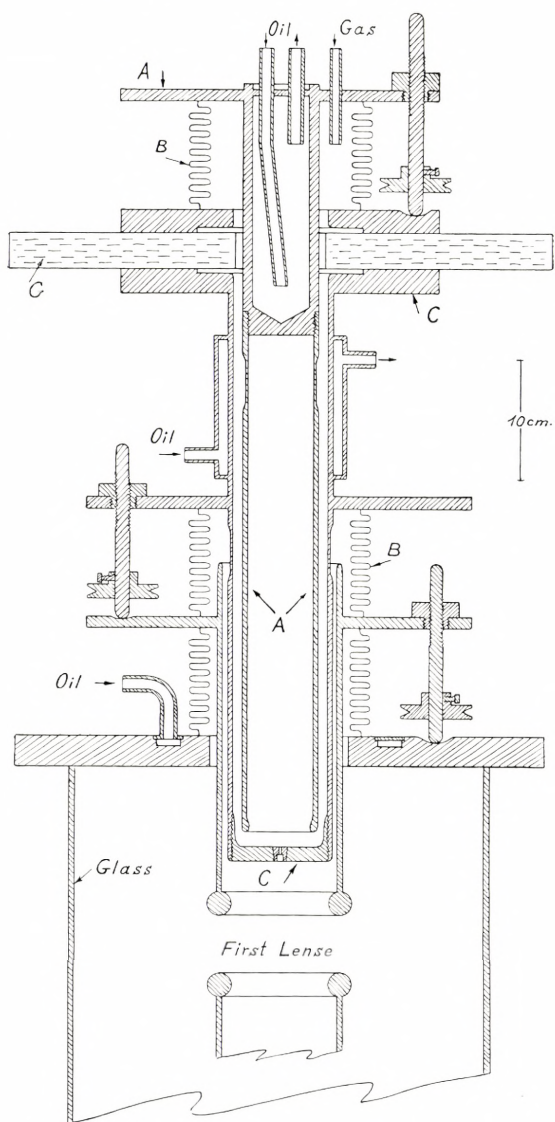

Fig. 11. High tension ion source. A: anode, C: cathode, B: vacuum tight bellows. G: glass insulator,

By means of vacuum tight bellows B, it is possible to adjust the positions of the various parts with respect to one another, with the aid of strings controlled from the observation room when high tension is on. Great care has been exercised to avoid joints between the oil-cooling system and the vacuum, the two systems being separated by solid material, without welds. It has since been found that oil cooling is unnecessary, a stream of air being quite sufficient.

The supply of hydrogen or deuterium comes from a flask situated in the corona shield on top of the tube; the rate of flow, approximately 30 microlitres/sec. at atmospheric pressure, is regulated by a needle valve which, together with a stopcock with which to close off the gas completely, can be controlled from the observation room. The discharge operates at a pressure of about 2×10^{-2} mm with a current of 1—3 m. a. at a voltage of 30 kV. Under these conditions, a narrow discharge column is formed along the axis, and ions emerge from the canal in a well-defined parallel beam. It is quite easy to obtain currents to the target of 100 to 150 microamperes. While it has not been possible on account of the pressure of other work to carry out precise measurements of the characteristics of the ion source, preliminary magnetic analysis indicate a large preponderance of atomic ions in the beam. Since the present ion source was constructed, a systematic investigation of this type of discharge ion source has been published by C. HAILER (1), from which it appears that comparatively small changes in construction may effect quite considerable improvements; however, preliminary attempts to introduce

¹ C. HAILER, *Wiss. Veröffentlich. a. d. Siemens-Werken*. XVII, 321. 1939.

these changes here did not result in the desired improvements, presumably because of the somewhat different dimensions in our source.

b) Power supply for the ion source.

In order to operate the ion source, we have constructed a special power supply for 30 kV and up to 20 milliamperes, insulated from ground for 10^6 volts (see Fig. 10). A motor at ground potential drives, by means of an insulating belt, a generator for 380 volts (200 cycles), the output of which is transformed to 30 kV and rectified. In series with the 30 kV supply is connected a resistance of 50,000 ohms for stabilising the gas discharge. Since the whole power plant is at a potential of up to one million volts, it is supported on a 3.5 m high turbonite cylinder and enclosed in a corona shield made in four parts to give easy access for inspection and repair.

It has appeared that wooden corona shields as used e. g. in the Cavendish Laboratory are very satisfactory. We have constructed them of thin plywood, the joints filled with plastic wood, and carefully smoothed by sandpapering. The surface of the wood is either metal-sprayed or covered with graphite paint; in both cases painted over by aluminium lacquer in order to protect and smooth the surface. All corona shields used here have been made in this manner.

Measuring instruments visible from below give the rectifier tube's filament current, transformer primary voltage, and the ion source current. The voltage to the transformer may be switched on by means of a pull string and the potential varied by means of a field rheostat controlled by another string. Connection to the ion source is made by

means of a lead brought through the corona shields in insulating bushings. The water resistance connections from the high tension generator to the accelerating tube are fastened to metal bands around the turbonite cylinder which thus serve both as mechanical support for the connections and to distribute the potential along the turbonite column.

c) The acceleration tube.

The acceleration tube is of the long ion path type, with eight electrical lenses, corresponding to the number of points with fixed potential on the high tension plant. Here we followed a suggestion by Dr. DEE, who pointed out to us the advantage of a multiple acceleration tube in connection with this particular type of high tension plant. The tube is, as shown in the drawing of Fig. 12, built up of glass cylinders separated by iron flanges, and stands on a heavy iron base to which pump connections are made. The ends of the glass cylinders are carefully ground plane in order to avoid the danger of their breaking when subjected to the pressure of about 1200 kg due to the atmosphere. Each iron flange carries inside the tube an iron cylinder upon the ends of which are mounted highly polished rings, which serve as components of their respective lenses. In order to obtain a homogeneous electric field along the outer wall of the tube to avoid surface sparks, which may easily puncture the glass, each flange is provided with a corona shield.

The vacuum joints were originally sealed with a fillet of Apiezon "Q" clay which seemed very tight and otherwise satisfactory. Inspection of the inner parts about a year after the first assembly revealed, however, that considerable quantities of oil had separated out from the clay and formed

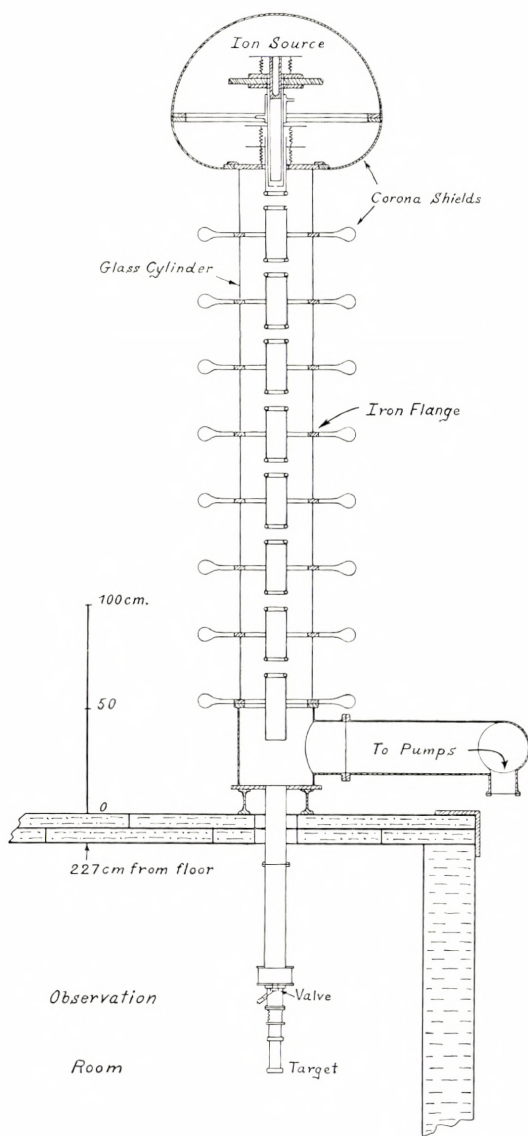

Fig. 12. Construction of acceleration tube with extension into observation room.

a film in a region for several centimeters around each joint. Since this oil under bombardment by stray particles can give rise to large quantities of gas and contamination of the target, it is highly undesirable in the tube. Therefore, the tube was carefully cleaned with ether and reassembled with thin rubber gaskets, made tight with glyptal lacquer. Some difficulty was at first encountered when voltage was applied, from puncturing of the joints by sparks between sections along the glass cylinders, but has been eliminated by shielding with a thin wire bound around the glass adjacent to the joints, and making contact to the flange.

The tube is extended on the lower end into the observation room by a brass tube containing a vacuum valve permitting rapid changing of targets, without letting air into the main tube. By means of a removable platinum foil in the target tube, the focal spot may be observed through a glass window, providing a convenient means of judging the performance of the tube.

Since the type of ion source used here delivers a small, almost parallel beam of relatively high velocity ions, focussing is not a very difficult problem. The first lense, with an accelerating potential of one eighth of the total voltage, is the most important, and the position of the exit canal of the ion source relative to this gap seems to determine the entire focussing. It seems to be important, however, that the remainder of the tube is carefully lined up, within a few millimetres. Under normal operation, after a short period of outgassing in the morning, the voltage on the tube is limited by external flashover, presumably caused by unsteadiness resulting from gas discharges within the tube. The pressure with voltage and current on is about 2×10^{-5} mm.

d) Vacuum equipment.

A very important requirement in obtaining steady operation of the tube is a high vacuum. In view of the fact that considerable quantities of gas enter the tube from the ion source, it would seem that very high pumping speeds would be necessary. For this reason, considerable attention was given to the design of the pumps. After some preliminary experiments and an extensive study of the literature, a satisfactory construction was developed and executed in three sizes, corresponding to the three stages desired for the system. As will be seen from the drawing of Fig. 13, the pumps are of the umbrella type, using Apiezon oils. The envelopes are constructed of stainless steel having low heat conductivity and the boilers are surrounded by a chromium plated heat shield of copper to minimise heat loss. All internal parts are also made of copper.

The pumping speeds for the three sizes used here are, at pressures $< 10^{-3}$ mm, 20, 50 and 140 litres of air per second for the 2", 3", and 5" size, respectively. In order to obtain the desired speed, the high vacuum stage was made to consist of three 5" pumps in parallel and backed by a 3" and a 2" pump in series. The rectifier column is provided with one 5" and one 2" pump. Forevacuum for both systems is furnished by a common mechanical pump consisting of two independent units placed in series. The whole pumping arrangement, which can be seen in position in Fig. 10, is shown on a larger scale in Fig. 14.

The pumping speed of the system on the ion tube is about 1100 litres of deuterium per second. The ultimate vacuum is less than 10^{-6} mm as estimated on the McLeod gauge. In order to prevent damage to the pumps by sudden

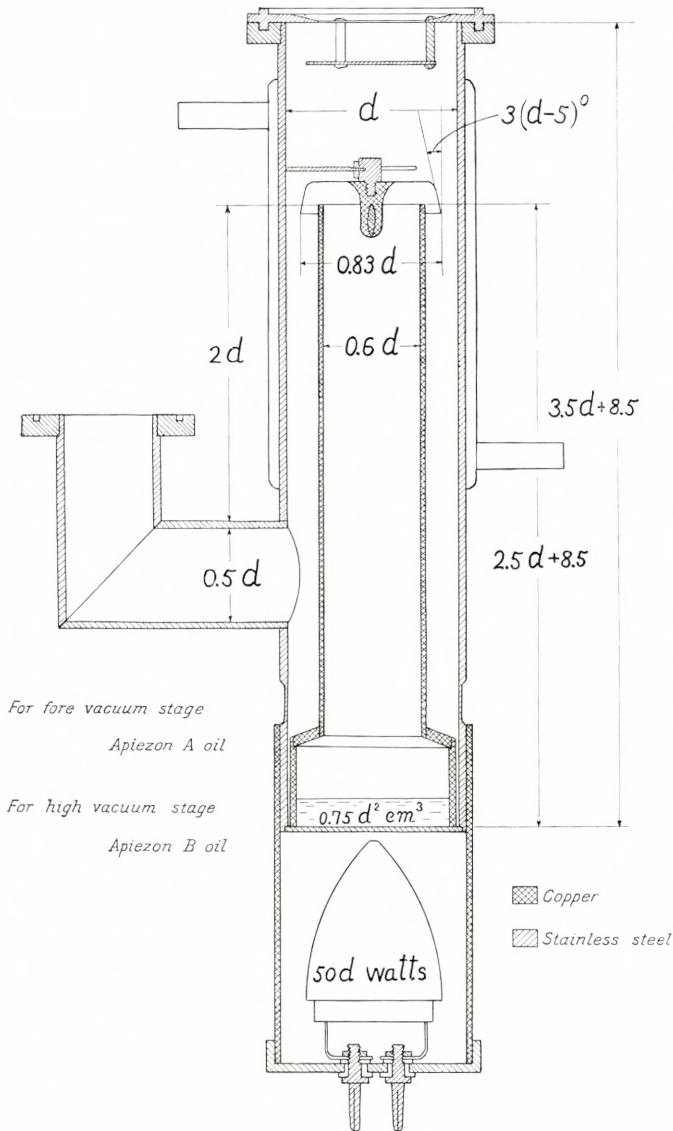

Fig. 13. Vacuum pump details. The dimensions of the pump, the amount of oil to be used and the heating power are given as functions of the diameter d of the envelope in cm.

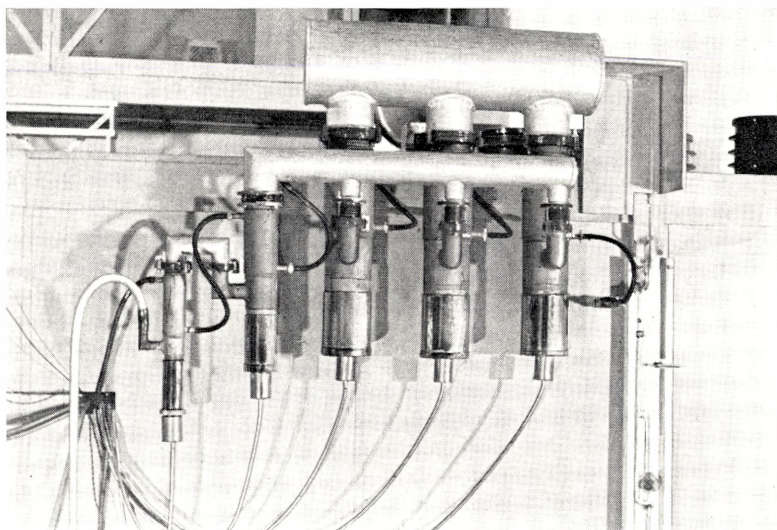

Fig. 14. Vacuum pump system used in connection with the acceleration tube consisting of three 5" pumps in parallel backed by a 3" and a 2" diffusion pump and a mechanical stage (not shown).

entry of air into the system, a relay, controlled by a manometer in the vacuum line, is provided to shut off the heater current. Failure of the water cooling or of the power supply to either of the mechanical pumps will also operate the relay.

In view of the fact that it is often convenient to use interchangeable parts on a vacuum system, it was considered wise more or less

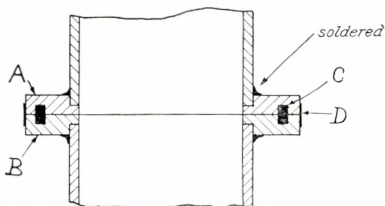

Fig. 15. Standard vacuum connection. A, B flanges held in position by the automobile piston ring C and made tight by a rubber band D and glyptal lacquer.

to standardise the fittings used in the laboratory on pumps and other connections. The type adopted here is indicated in the diagram Fig. 15. The ends of two tubes to be joined are pro-

vided with flanges A and B, which are held together with C-clamps. In the space, which consists of the two adjoining grooves turned in the flanges, lies a common automobile piston ring C. The joint is made vacuum tight by a broad rubber band D, which is painted with glyptal lacquer. It is to be observed that the two flanges are exactly alike; there are no positive and negative flanges. The flanges are standardised in five sizes, corresponding to 2", 3", 4", 5" and 10" tubing.

V. Observation room equipment.

An idea of the inside of the observation room in the high tension hall is given by the photograph Fig. 16 taken from the north west corner of the room (see Fig. 1). In the centre of the picture, projecting through the ceiling, is the target tube extension fitted with the various attachments for adjusting the target. To the left is the portable control desk for the high tension set with the necessary meters. An extra meter directly indicating the high voltage measured by the current through the high tension resistance in the hall, is mounted on the wall to the right, over the sink. An apparatus for electrolysing heavy water to obtain deuterium for the ion source is shown at the extreme right. Electrical controls for the power stack motor are mounted on the wall to the left of the sink. Direct controls to the ion source come through the ceiling near the target tube.

In Fig. 17 is shown on a larger scale the target tube extension in connection with a particular working arrangement, that used in the cloud chamber study of fission tracks mentioned in the introduction. Neutrons coming from a beryllium target in the bottom of the tube are allowed to

fall on foils carrying uranium within the cloud chamber behind. Stereoscopic photographs are taken with a Leica camera and a mirror system mounted on top of the chamber, illumination being provided by lamps in the metal boxes at the sides. In actual use, the chamber and target tube

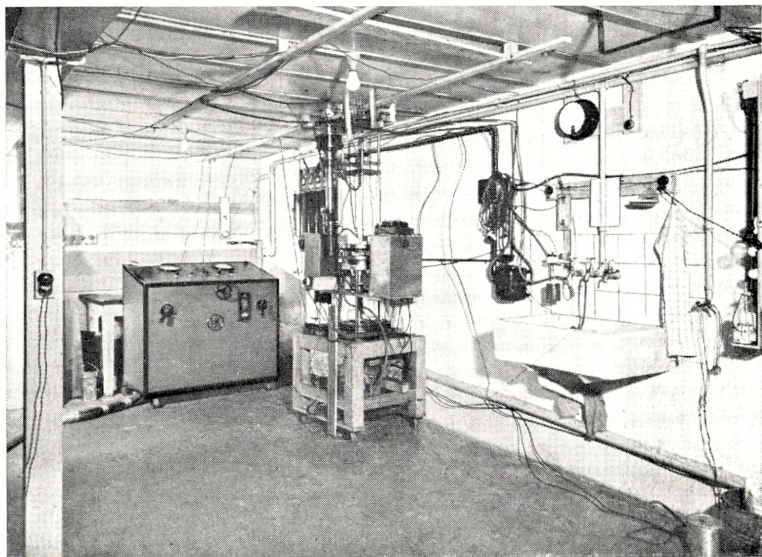

Fig. 16. Interior of the observation room.

are surrounded by thick paraffine blocks to slow down the neutrons. This equipment, together with other auxiliary apparatus, will be more fully described in the publications giving the results of investigations carried out in the laboratory.

At the conclusion of this account, the authors wish to take the opportunity to express their gratitude to Professor N. BOHR, under whose direction the work has been carried

out, for constant encouragement and unfailing interest. It is also a pleasure to acknowledge the helpful cooperation of many individuals and firms in the construction work.

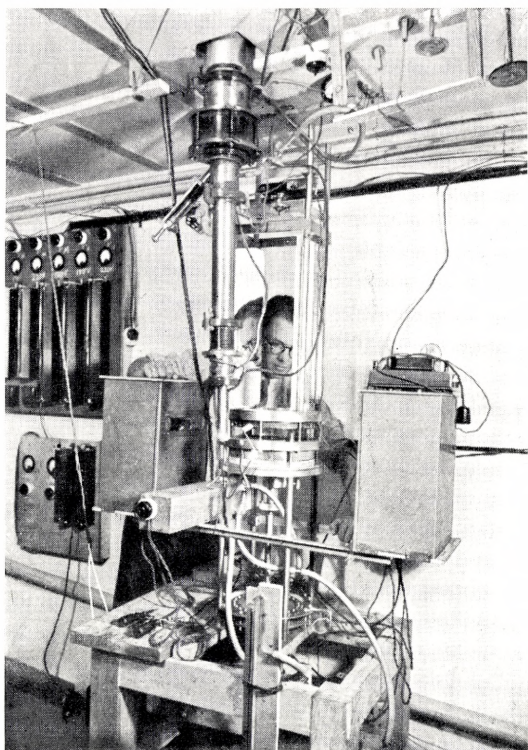

Fig. 17. Target tube and cloud chamber.

The invaluable help of Professors v. HIPPEL, COCKCROFT, DEE, OLIPHANT and LAURITSEN has already been mentioned. In addition, we have had much advice and assistance from Dr. JACOBSEN, Dr. RASMUSSEN, and cand. mag. HYLLING CHRISTENSEN and from a number of other collaborators at the Institute. Also, we are particularly indebted to the machine shop staff under the leadership of Mr. H. W.

OLSEN for the fabrication of the many special metal parts, and to Mr. A. JENSEN who has made the most satisfactory wooden corona shields in the carpenter shop. Besides to the firm KOCH & STERZEL for most helpful and valuable cooperation in connection with their construction of the generator, our thanks are due the engineering firm STEENSEN & VARMING and the THS. B. THRIGE Co. for assistance with various technical installations.

CONTENTS

	Page
Introduction.....	3
I. Building arrangements	6
II. High tension set.....	8
III. Rectifier column	15
IV. Ion production and acceleration system	22
V. Observation room equipment.....	33

Figures :

1. Plan of building.....	7	10. Acceleration tube and power stack.....	23
2. Electrical circuit of generator	9	11. Ion source	24
3. View of generator set ..	10—11	12. Construction of accelera- tion tube	28
4. Voltmeter resistance before assembly	12	13. Vacuum pump details....	31
5. Voltmeter resistance installed	13	14. Vacuum pump system ...	32
6. Rectifier column diagram..	16	15. Standard vacuum connec- tion	32
7. Modified electrical circuit of generator	18	16. Interior of observation room	34
8. Photograph of discharge... 19		17. Target tube and cloud chamber	35
9. High tension generator with modifications	21		

